

THIEF RIVER FALLS CITY COUNCIL AGENDA

Monday, January 9, 2023

COUNCIL CHAMBERS
CITY HALL – 405 3RD STREET EAST
4:00 PM

1. CALL TO ORDER
2. PLEDGE OF ALEGIANCE
3. ROLL CALL
4. PUBLIC FORUM - *Individuals may address the City Council about any item not included on the regular agenda. A maximum of 5 minutes is allotted for the public forum. The City Council will not take official action on items discussed at this time, with the exception of referral to staff or a committee, board or commission for a future report.*
5. PRESENTATIONS/PROCLAMATIONS/PUBLIC INFORMATION ANNOUNCEMENTS
6. APPROVE AGENDA - *Council members may add items to the agenda for discussion purposes or staff direction. The Council will not normally take official action on items added to the agenda.*
7. CONSENT AGENDA - *These items are considered routine in nature and are approved with one motion without discussion/debate. The Mayor will ask if any Council member wishes to remove an item and place it on the regular agenda for discussion and consideration. If no items are to be removed, the Mayor will then ask for a motion to approve the Consent Agenda.*
8. NEW BUSINESS
 - 8.1. Approve License Renewal Application for Northland Taxi
9. COUNCIL BOARDS AND COMMISSIONS REPORTS - *Not all boards or commissions will have met prior to the Council meeting. These reports are intended to keep the other council members informed of actions or proposed actions taken by these boards and commissions. Only those with something to report would be on the agenda.*
10. UPCOMING MEETINGS

11. INFORMATIONAL ITEMS

12. ADJOURNMENT

City of Thief River Falls complies with the ADA. Individuals with disabilities requiring special aids should contact the City Administrator, 405 Third Street East, Thief River Falls, MN 56701, 218-681-2943, 48 hours prior to the scheduled meeting.



City of Thief River Falls

405 Third Street East • PO Box 528
Thief River Falls MN 56701-0528

PHONE: 218-681-2943
FAX: 218-681-6223
email: @citytrf.net
www.citytrf.net

Request for Council Action

DATE: 1/9/2023

SUBJECT:

RECOMMENDATION:

MOTION TO:

BACKGROUND:

KEY ISSUES:

FINANCIAL CONSIDERATIONS:

LEGAL CONSIDERATION:

DEPARTMENT/RESPONSIBLE PERSON:

ATTACHMENTS:

1.	Northland Taxi Renewal Application 2023
2.	Northland Taxi Renewal Application 2023 - 2
3.	Northland Taxi Renewal Application 2023-3



CITY OF THIEF RIVER FALLS

License Renewal Application

Pursuant to City Code Chapter 110

LICENSING PERIOD: January 1 2023 – December 31 2023

TYPE OF LICENSE #1: Taxi \$30/1st Taxi \$25/each add'l

TYPE OF LICENSE #2:

TYPE OF LICENSE #3:

BUSINESS NAME: Northland Taxi

BUSINESS ADDRESS: 518 Knight Ave N Thief River Falls MN 56701

BUSINESS PHONE:

CONTACT NAME: Randall Anenson

CONTACT ADDRESS: 518 Knight Ave N Thief River Falls MN 56701

I certify that the above information is correct: (Please check if correct)

-or-

Please make the following changes: _____

Applicant understands that all information contained on this application is public data according to Chapter 13 of the Minnesota State Statute.

Applicant shall comply with all restrictions, limitations, and regulations under the City Code and State Statutes

I authorize investigation of all statements contained in this application. I understand that the misrepresentation, or the omission of facts called for, will be just cause for denying the license(s).

Randall N. Anenson
SIGNATURE OF APPLICANT

11-2-22
DATE

For Office Use Only:

DATE APPLICATION RECEIVED 12/28/22

DATE OF COUNCIL ACTION _____

PAID \$30.00 12/30/22
INSURANCE



CC0515

Mailing Address:
 PO Box 64217
 St. Paul, MN 55164-0217

Certificate of Compliance Minnesota Workers' Compensation Law

This form must be completed by the business license applicant.

Email: dli.license@state.mn.us
 Website: dli.mn.gov
 Phone: (651) 284-5034

Print in ink or type

Minnesota Statutes § 176.182 requires every state and local licensing agency to withhold the issuance or renewal of a license or permit to operate a business in Minnesota until the applicant presents acceptable evidence of compliance with the workers' compensation insurance coverage requirement of Minn. Stat. chapter 176. If the required information is not provided or is falsely stated, it shall result in a \$2,000 penalty assessed against the applicant by the commissioner of the Department of Labor and Industry.

A valid workers' compensation policy must be kept in effect at all times by employers as required by law.

License or certificate number (if applicable)	Business telephone number 218-416-0888	Alternate telephone number
---	--	----------------------------

Business name (Provide the legal name of the business entity. If the business is a sole proprietor or partnership, provide the owner's name(s), for example John Doe, or John Doe and Jane Doe.)

DBA ("doing business as" or "also known as" an assumed name), if applicable

DBA Northland Taxi			
Business address (must be physical street address, no P.O. boxes) 518 Knight Ave. N.	City Thief River Falls	State MN	ZIP code 56701
County Pennington	Email address ranenson@hotmail.com		

You must complete number 1 or 2 below.

Note: You must resubmit this form to the authority issuing your license if any of the information you have provided changes.

1. **I have a workers' compensation insurance policy.**

Insurance company name (not the insurance agent)

Policy number:	Effective date:	Expiration date:
----------------	-----------------	------------------

I am self-insured for workers' compensation. (Attach a copy of the authorization to self-insure from the Minnesota Department of Commerce; see <https://mn.gov/commerce/industries/insurance/licensing/self-insurance>.)

2. **I am not required to have workers' compensation insurance because:**

- I only use independent contractors and do not have employees. (See [Minn. Stat. § 176.043](#) for trucking and messenger courier industries; [Minn. Stat. § 181.723, subd. 4](#), for building construction; and [Minnesota Rules chapter 5224](#) for other industries.)
- I do not use independent contractors and have no employees. (See [Minn. Stat. § 176.011, subd. 9](#), for the definition of an employee.)
- I use independent contractors and I have employees who are not required to be covered by the workers' compensation law. (Explain below.)
- I only have employees who are not required to be covered by the workers' compensation law. (Explain below.) (See [Minn. Stat. § 176.041](#) for a list of excluded employees.)

Explain why your employees are not required to be covered

I certify the information provided on this form is accurate and complete. If I am signing on behalf of a business, I certify I am authorized to sign on behalf of the business.

Print name: **Randall N. Anenson**

Applicant signature (required) Randall N. Anenson	Title Owner	Date 11-2-22
---	-----------------------	------------------------

If you have questions about completing this form or to request this form in braille, large print or audio.



CERTIFICATE OF LIABILITY INSURANCE

DATE (MM/DD/YYYY)
01/03/2023

THIS CERTIFICATE IS ISSUED AS A MATTER OF INFORMATION ONLY AND CONFERS NO RIGHTS UPON THE CERTIFICATE HOLDER. THIS CERTIFICATE DOES NOT AFFIRMATIVELY OR NEGATIVELY AMEND, EXTEND OR ALTER THE COVERAGE AFFORDED BY THE POLICIES BELOW. THIS CERTIFICATE OF INSURANCE DOES NOT CONSTITUTE A CONTRACT BETWEEN THE ISSUING INSURER(S), AUTHORIZED REPRESENTATIVE OR PRODUCER, AND THE CERTIFICATE HOLDER.

IMPORTANT: If the certificate holder is an ADDITIONAL INSURED, the policy(ies) must have ADDITIONAL INSURED provisions or be endorsed. If SUBROGATION IS WAIVED, subject to the terms and conditions of the policy, certain policies may require an endorsement. A statement on this certificate does not confer rights to the certificate holder in lieu of such endorsement(s).

PRODUCER		CONTACT NAME: Lisa Rhen	
North Risk Partners		PHONE (A/C, No, Ext): (218) 681-1714	FAX (A/C, No): (218) 681-8099
2017 Highway 59 SE		E-MAIL ADDRESS: lisa.rhen@northriskpartners.com	
Thief River Falls MN 56701		INSURER(S) AFFORDING COVERAGE	
		INSURER A: National Continental Insurance Company	NAIC # 10243
INSURED		INSURER B:	
Randall Anenson, DBA: Northland Taxi		INSURER C:	
518 Knight Ave N		INSURER D:	
Thief River Falls MN 56701		INSURER E:	
		INSURER F:	

COVERAGES CERTIFICATE NUMBER: CL231376748 REVISION NUMBER:

THIS IS TO CERTIFY THAT THE POLICIES OF INSURANCE LISTED BELOW HAVE BEEN ISSUED TO THE INSURED NAMED ABOVE FOR THE POLICY PERIOD INDICATED. NOTWITHSTANDING ANY REQUIREMENT, TERM OR CONDITION OF ANY CONTRACT OR OTHER DOCUMENT WITH RESPECT TO WHICH THIS CERTIFICATE MAY BE ISSUED OR MAY PERTAIN, THE INSURANCE AFFORDED BY THE POLICIES DESCRIBED HEREIN IS SUBJECT TO ALL THE TERMS, EXCLUSIONS AND CONDITIONS OF SUCH POLICIES. LIMITS SHOWN MAY HAVE BEEN REDUCED BY PAID CLAIMS.

INSR LTR	TYPE OF INSURANCE	ADDL INSD	SUBR WVD	POLICY NUMBER	POLICY EFF (MM/DD/YYYY)	POLICY EXP (MM/DD/YYYY)	LIMITS
	COMMERCIAL GENERAL LIABILITY <input type="checkbox"/> CLAIMS-MADE <input type="checkbox"/> OCCUR GEN'L AGGREGATE LIMIT APPLIES PER: <input type="checkbox"/> POLICY <input type="checkbox"/> PRO-JECT <input type="checkbox"/> LOC OTHER:						EACH OCCURRENCE \$ DAMAGE TO RENTED PREMISES (Ea occurrence) \$ MED EXP (Any one person) \$ PERSONAL & ADV INJURY \$ GENERAL AGGREGATE \$ PRODUCTS - COMP/OP AGG \$ \$
A	AUTOMOBILE LIABILITY <input type="checkbox"/> ANY AUTO <input type="checkbox"/> OWNED AUTOS ONLY <input checked="" type="checkbox"/> SCHEDULED AUTOS <input type="checkbox"/> HIRED AUTOS ONLY <input type="checkbox"/> NON-OWNED AUTOS ONLY <input type="checkbox"/>			22364600011	01/09/2022	01/09/2023	COMBINED SINGLE LIMIT (Ea accident) \$ 300,000 BODILY INJURY (Per person) \$ BODILY INJURY (Per accident) \$ PROPERTY DAMAGE (Per accident) \$ \$
	UMBRELLA LIAB <input type="checkbox"/> OCCUR EXCESS LIAB <input type="checkbox"/> CLAIMS-MADE DED RETENTION \$						EACH OCCURRENCE \$ AGGREGATE \$ \$
	WORKERS COMPENSATION AND EMPLOYERS' LIABILITY ANY PROPRIETOR/PARTNER/EXECUTIVE OFFICER/MEMBER EXCLUDED? (Mandatory in NH) If yes, describe under DESCRIPTION OF OPERATIONS below		Y/N N/A				PER STATUTE OTH-ER E.L. EACH ACCIDENT \$ E.L. DISEASE - EA EMPLOYEE \$ E.L. DISEASE - POLICY LIMIT \$

DESCRIPTION OF OPERATIONS / LOCATIONS / VEHICLES (ACORD 101, Additional Remarks Schedule, may be attached if more space is required)
Auto policy currently covers liability for the following vehicle,

2008 Chrysler Town & Country #1388

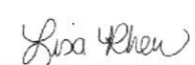
CERTIFICATE HOLDER City of Thief River Falls 405 3rd Street East PO Box 528 Thief River Falls MN 56701	CANCELLATION SHOULD ANY OF THE ABOVE DESCRIBED POLICIES BE CANCELLED BEFORE THE EXPIRATION DATE THEREOF, NOTICE WILL BE DELIVERED IN ACCORDANCE WITH THE POLICY PROVISIONS.
	AUTHORIZED REPRESENTATIVE 

© 1988-2015 ACORD CORPORATION. All rights reserved.



CERTIFICATE OF LIABILITY INSURANCE

DATE (MM/DD/YYYY)
12/29/2022

THIS CERTIFICATE IS ISSUED AS A MATTER OF INFORMATION ONLY AND CONFERS NO RIGHTS UPON THE CERTIFICATE HOLDER. THIS CERTIFICATE DOES NOT AFFIRMATIVELY OR NEGATIVELY AMEND, EXTEND OR ALTER THE COVERAGE AFFORDED BY THE POLICIES BELOW. THIS CERTIFICATE OF INSURANCE DOES NOT CONSTITUTE A CONTRACT BETWEEN THE ISSUING INSURER(S), AUTHORIZED REPRESENTATIVE OR PRODUCER, AND THE CERTIFICATE HOLDER.

IMPORTANT: If the certificate holder is an ADDITIONAL INSURED, the policy(ies) must have ADDITIONAL INSURED provisions or be endorsed. If SUBROGATION IS WAIVED, subject to the terms and conditions of the policy, certain policies may require an endorsement. A statement on this certificate does not confer rights to the certificate holder in lieu of such endorsement(s).

PRODUCER North Risk Partners 2017 Highway 59 SE Thief River Falls MN 56701	CONTACT NAME: Lisa Rhen PHONE (A/C, No, Ext): (218) 681-1714 FAX (A/C, No): (218) 681-8099 EMAIL ADDRESS: lisa.rhen@northriskpartners.com																				
	<table border="1"> <tr> <th colspan="2">INSURER(S) AFFORDING COVERAGE</th> <th>NAIC #</th> </tr> <tr> <td>INSURER A:</td> <td>National Continental Insurance Company</td> <td>10243</td> </tr> <tr> <td>INSURER B:</td> <td></td> <td></td> </tr> <tr> <td>INSURER C:</td> <td></td> <td></td> </tr> <tr> <td>INSURER D:</td> <td></td> <td></td> </tr> <tr> <td>INSURER E:</td> <td></td> <td></td> </tr> <tr> <td>INSURER F:</td> <td></td> <td></td> </tr> </table>	INSURER(S) AFFORDING COVERAGE		NAIC #	INSURER A:	National Continental Insurance Company	10243	INSURER B:			INSURER C:			INSURER D:			INSURER E:			INSURER F:	
INSURER(S) AFFORDING COVERAGE		NAIC #																			
INSURER A:	National Continental Insurance Company	10243																			
INSURER B:																					
INSURER C:																					
INSURER D:																					
INSURER E:																					
INSURER F:																					
INSURED Randall Anenson, DBA: Northland Taxi 518 Knight Ave N Thief River Falls MN 56701																					

COVERAGES **CERTIFICATE NUMBER:** CL222252450 **REVISION NUMBER:**

THIS IS TO CERTIFY THAT THE POLICIES OF INSURANCE LISTED BELOW HAVE BEEN ISSUED TO THE INSURED NAMED ABOVE FOR THE POLICY PERIOD INDICATED. NOTWITHSTANDING ANY REQUIREMENT, TERM OR CONDITION OF ANY CONTRACT OR OTHER DOCUMENT WITH RESPECT TO WHICH THIS CERTIFICATE MAY BE ISSUED OR MAY PERTAIN, THE INSURANCE AFFORDED BY THE POLICIES DESCRIBED HEREIN IS SUBJECT TO ALL THE TERMS, EXCLUSIONS AND CONDITIONS OF SUCH POLICIES. LIMITS SHOWN MAY HAVE BEEN REDUCED BY PAID CLAIMS.

INSM LTR	TYPE OF INSURANCE	POLICY PERIOD		POLICY NO.	POLICY EFF. (MM/DD/YYYY)	POLICY EXP. (MM/DD/YYYY)	LIMITS	
		INSD	WVD					
	COMMERCIAL GENERAL LIABILITY <input type="checkbox"/> CLAIMS-MADE <input type="checkbox"/> OCCUR GEN'L AGGREGATE LIMIT APPLIES PER: <input type="checkbox"/> POLICY <input type="checkbox"/> PRO-JECT <input type="checkbox"/> LOC OTHER						EACH OCCURRENCE \$ DAMAGE TO RENTED PREMISES (Ea occurrence) \$ MED EXP (Any one person) \$ PERSONAL & ADV INJURY \$ GENERAL AGGREGATE \$ PRODUCTS - COM/OP AGG \$	
A	AUTOMOBILE LIABILITY <input type="checkbox"/> ANY AUTO <input type="checkbox"/> OWNED AUTOS ONLY <input checked="" type="checkbox"/> SCHEDULED AUTOS <input type="checkbox"/> HIRED AUTOS ONLY <input type="checkbox"/> UNOWNED AUTOS ONLY <input type="checkbox"/> AUTOS ONLY			CMN000-5173-500-2	01/09/2022	01/09/2023	COMBINED SINGLE LIMIT (Ea accident) \$ BODILY INJURY (Per person) \$ 100,000 BODILY INJURY (Per accident) \$ 300,000 PROPERTY DAMAGE (Per accident) \$	
	UMBRELLA LIAB <input type="checkbox"/> OCCUR EXCESS LIAB <input type="checkbox"/> CLAIMS-MADE DED RETENTION \$						EACH OCCURRENCE \$ AGGREGATE \$	
	WORKERS COMPENSATION AND EMPLOYERS' LIABILITY ANY PROPRIETOR/PARTNER/EXECUTIVE OFFICER/MEMBER EXCLUDED? (Mandatory in NH) if yes, describe under DESCRIPTION OF OPERATIONS below	Y/N	N/A				PER STATUTE OTH-ER E.L. EACH ACCIDENT \$ E.L. DISEASE - EA EMPLOYEE \$ E.L. DISEASE - POLICY LIMIT \$	

DESCRIPTION OF OPERATIONS / LOCATIONS / VEHICLES (ACORD 101, Additional Remarks Schedule, may be attached if more space is required)

Auto policy currently covers liability for a maximum of 2 scheduled vehicles.

CERTIFICATE HOLDER

Randall Anenson dba Northland Taxi
 518 Knight Ave N
 Thief River Falls MN 56701

CANCELLATION

SHOULD ANY OF THE ABOVE DESCRIBED POLICIES BE CANCELLED BEFORE THE EXPIRATION DATE THEREOF, NOTICE WILL BE DELIVERED IN ACCORDANCE WITH THE POLICY PROVISIONS.

AUTHORIZED REPRESENTATIVE

CITY OF THIEF RIVER FALLS "ASE" MECHANIC INSPECTION

NAME OF COMPANY	Northland Taxi
REGISTERED OWNER OF VEHICLE	Randall Anenson
ADDRESS	518 Knight Ave. N. Thief River Falls, MN 56701
PHONE(S)	218-681-6666 / 218-416-0888

VEHICLE INFORMATION	
MODEL YEAR	2008
MAKE	Chrysler
MODEL	Town & Country
VIN#	2A8HR54P48R841388
LICENSE PLATE #/STATE	

CODE	ITEM	PASS	FAIL
A	GLASS	X	
B	MIRRORS	X	
C	SEATS	X	
D	SEAT BELTS	X	
E	HEADLIGHTS	X	
F	TAIL LIGHTS	X	
G	TURN SIGNALS	X	
H	BRAKE LIGHTS	X	
I	TAG LIGHTS	X	
J	BACK UP LIGHTS	X	
K	WIPERS	X	

CODE	ITEM	PASS	FAIL
L	HORN	X	
M	TIRES	X	
N	BRAKES	X	
O	EMERGENCY BRAKES	X	
P	EXHAUST	X	
Q	GAS	X	
R	STEERING	X	
S	DRIVE LINE/SUSPENSION	X	
T	SPARE TIRE	X	
U	ENGINE	X	

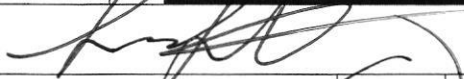
REMARKS			
INSPECTION	PASS	FAIL	
MECHANIC'S NAME/SIGNATURE			
IS MECHANIC "ASE" CERTIFICATION ATTACHED? (REQUIRED)	YES	NO	

TAXI INSPECTION FORM CODES AND DEFINITIONS
REASON FOR FAILURE

A	GLASS: ANY BROKEN OR MISSING GLASS; WINDSHIELD CRACKS INTERFERING WITH DRIVER'S VISION OR PASSENGER SAFETY
B	MIRRORS: MISSING, CREAKED OR BROKEN TO THE EXTENT TO OBSTRUCT VISION
C	SEATS: BROKEN SPRINGS, TEARS OR RIPS IN UPHOLSTERY OVER TWO INCHES THAT COULD INTERFERE WITH ENTRY AND EXIT
D	SEAT BELTS: ANY MISSING COMPONENT; ANY LOCKS THAT WILL NOT ENGAGE OR DISENGAGE; TEARS OR RIPS IN FABRIC BELTS
E	HEADLIGHTS: ANY LIGHT NOT FUNCTION- ING TO INCLUDE HIGH AND LOW BEAMS
F	TAIL LIGHTS: ANY BULB NOT WORKING; GLASS OR PLASTIC COVER BROKEN
G	TURN SIGNALS: ANY BULB NOT WORKING; GLASS OR PLASTIC COVER BROKEN
H	BRAKE LIGHTS: ANY BULB NOT WORKING; GLASS OR PLASTIC COVER BROKEN
I	TAG LIGHTS: ANY BULB NOT WORKING; GLASS OR PLASTIC COVER BROKEN
J	BACK UP LIGHTS: ANY BULB NOT WORKING; GLASS OR PLASTIC COVER BROKEN
K	WIPERS: NOT WORKING, BLADES HARD, CRACKED, FRAYED OR RIPPED

L	HORN: INOPERATIVE
M	TIRES: TREAD DEPTH LESS THAN 4/32", TIRES THAT HAVE VISIBLE CORD OR METAL, REGROOVED OR SIDE PLUG
N	BRAKES: FRONT/REAR DISK BRAKE LESS THAN 15% USABLE PAD REMAINING, ROTOR NOT WITHIN MANUFACTURER SPEC. REAR DRUMS: LESS THAN 15% USABLE SHOE REMAINING, LEAKING IN CALIPER, WHEEL CYLINDER, MASTER CYLINDER AND/OR LINE
O	EMERGENCY BRAKES: NOT WORKING/NOT HOLDING VEHICLE
P	LEAKS: EXHAUST LEAK
Q	GAS: GAS LEAK
R	STEERING: LOOSENESS ANYWHERE EXCEEDING 1/8", MISSING BOLTS OR BENT COMPONENTS, POWER STEERING PUMP OR LINE LEAKS
S	DRIVE LINE/SUSPENSION: SHOCKS LEAKING, WON'T RECOVER WHEN VEHICLE IS PUSHED DOWNWARD; BROKEN OR DETERIORATED MOTOR OR TRANSMISSION MOUNTS; TRANSMISSION NOT WORKING PROPERLY, NOT SHIFTING SMOOTHLY; U-JOINTS LOOSE, DRIVE SHAFT BENT, SPRINGS CRACKED OR BROKEN
T	SPARE TIRE: TIRE DEPTH LESS THAN 4/32", NO CAR JACK AND/OR NO TIRE CHANGING TOOL
U	ENGINE: ENGINE DOES NOT RUN SMOOTHLY; KNOCKS, HEAVY EXHAUST SMOKE

Vehicle Cost -RO Detail Report

	Stock Nbr: 8R841388F	VIN: 2A8HR54P48R841388	
Type:	USED	Open Date:	08/12/22
Year:	2008	Close Date:	08/15/22
Make:	CHRYSLER	RO Number:	343700
Model:	TOWN & COUNTRY	PO Number:	
		Addl Charges:	94.87
		RO Total:	2404.54
		Estimate:	
		Mileage:	185,700

Description	Parts	Labour	Misc
* PERFORM VALUE AUTO PREP (AS-IS VEHICLES WITH GREATER THAN 80,000 MILES). MUST HAVE COMPLETE INSPECTION DOCUMENTING ALL VEHICLE CONCERNS. CONCERNS MUST BE PRICED IN ACE. LIST OF CONCERNS MUST GO W/IT	0.00	187.50	0.00
* PERFORM FORD VEHICLE MULTIPOINT INSPECTION	31.95	0.00	0.00
* BATTERY CONDITION IS GOOD	0.00	0.00	0.00
* BRAKE LININGS ARE OK AT THIS TIME.	0.00	0.00	0.00
* TIRE TREAD AND WEAR IS OK AT THIS TIME.	0.00	0.00	0.00
* INSTALL ASSURED PREMIUM VISION WIPER BLADES REAR WIPER BLADE	0.00	4.05	0.00
* UNDER HOOD WASHER JETS BROKEN (2) HOOD WASHER JETS	50.15	81.81	0.00
* REAR HATCH WIPER MOTOR INOP, WIPER MOTOR ASSEMBLY WITH EXTERIOR WIPER ARM AND NUT	392.89	147.79	0.00
* INSTALL EXTERIOR BULBS DRIVER FRONT SIDE MARKER	5.85	7.95	0.00
* INSTALL EXTERIOR BULBS PASSENGER FRONT SIDE MARKER	5.85	7.95	0.00
* REPLACE FRONT BRAKE PADS AND ROTORS	314.95	123.00	0.00
* CKE P1404, P0404, EGR FAILED, EGR VALVE ASSEMBLY AND GASKETS	217.76	299.82	0.00
* AC NOT BLOWING COLD, ARI CONDITIONING RECHARGE, INSTALL DYE INSPECT FOR LEAK, DIAG	53.40	179.49	0.00
* INTERNAL LOF	27.00	21.21	0.00
* INSPECT & REPLACE AIR FILTER ELEMENT AS NECESSARY, CLEAN AIR INTAKE TUBE	23.95	7.95	0.00
* INSTALL NEW WIPER BLADES	23.90	7.95	0.00
* FORD USED VEHICLE INSPECTION CHECKLIST	0.00	50.00	0.00
* WINDSHIELD WASHER FLUID	5.60	0.00	0.00
* ROTATE TIRES, CHECK TIRE CONDITION, AND INFLATE TIRES TO PRESSURE LISTED ON DOOR PLACARD.	0.00	29.95	0.00
Totals:	1,153.25	1,156.42	0.00

NORTHLAND TAXI

RATES

IN TOWN ONLY \$10 ONE WAY

INTERNAL

Invoice #: 343790

Tag #: AO1388



LITHIA FORD LINCOLN OF GRAND FORKS #176

2273 32nd AVENUE S - GRAND FORKS, ND 58201

PHONE: (701) 746-6411 FAX: (701) 787-8912

REMIT PAYMENT TO: LITHIA MOTORS SUPPORT SERVICES PO BOX 675-811, Dallas, TX 75267-9811

Home: Bus: Customer #:

Cell: Email: Service Advisor: 250858 AARON OLSON

Table with columns: COLOR, YEAR, MAKE/MODEL, VIN, LICENSE, MILEAGE IN, MILEAGE OUT, DEL DATE, PRCD. DATE, WARR. EXP., PROMISED, PO NO., RATE, PAYMENT, INV. DATE, R.O. OPENED, READY

OPTIONS: STK:8R841388F ENG:3.8 L ter_SMP1

Main service list table with columns: LINE OPCODE, TECH, TYPE, HOURS, LIST, NET, TOTAL. Includes items like FOR LEAK, DIAG, AC NOT BLOWING COLD, AIR CONDITIONING RECHARGE, etc.

"I acknowledge notice and oral approval of an increase in the original estimated price. Signature or initials"

STATEMENT OF DISCLAIMER AND ARBITRATION AGREEMENT

The factory warranty constitutes all of the warranties with respect to the sale of this item/items. The Seller hereby expressly disclaims all warranties either express or implied, including any implied warranty of merchantability or fitness for a particular purpose.

CUSTOMER SIGNATURE

ON BEHALF OF SERVING DEALER, I HEREBY CERTIFY THAT THE INFORMATION CONTAINED HEREON IS ACCURATE UNLESS OTHERWISE SHOWN. SERVICES DESCRIBED WERE PERFORMED AT NO CHARGE TO OWNER. THERE WAS NO INDICATION FROM THE APPEARANCE OF THE VEHICLE OR OTHERWISE, THAT ANY PART REPAIRED OR REPLACED UNDER THIS CLAIM HAD BEEN CONNECTED IN ANY WAY WITH ANY ACCIDENT, NEGLIGENCE OR MISUSE. RECORDS SUPPORTING THIS CLAIM ARE AVAILABLE FOR (1) YEAR FROM THE DATE OF PAYMENT NOTIFICATION AT THE SERVING DEALER FOR INSPECTION BY MANUFACTURER'S REPRESENTATIVE.

(PRINTED) DEALER GENERAL MANAGER OR AUTHORIZED PERSON (DATE)

Summary table with columns: LABOR AMOUNT, PARTS AMOUNT, GAS, OIL, LUBE, SUBLET AMOUNT, MISC. CHARGES, TOTAL CHARGES, LESS IN'S/DED/DIS, SALES TAX, PLEASE PAY THIS AMOUNT. Includes a vertical 'TOTALS' column.

INTERNAL

Invoice #: 343790

Tag #: AO1388

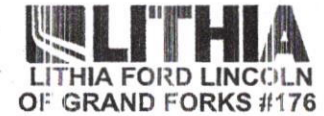

2273 32nd AVENUE S · GRAND FORKS, ND 58201

PHONE: (701) 746-6411 · FAX: (701) 787-8912

REMIT-PAYMENT TO: LITHIA MOTORS SUPPORT SERVICES

PO BOX 679811 · Dallas, TX 75267-9811

Home: Bus Customer #:

Cell: Email Service Advisor: 250858 AARON OLSON

COLOR	YEAR	MAKE/MODEL	VIN	LICENSE	MILEAGE IN	MILEAGE OUT			
	08	CHRYSLER TOWN & COUN	2AHR54P48R841388		185700	185700			
DEL DATE	PROD. DATE	WARR. EXP.	PROMISED	FD NO.	RATE	PAYMENT	INV. DATE	R.O. OPENED	READY
04AUG22			16:00 13AUG22		0.00	CASH	15AUG22	17:44 12AUG22	16:33 15AUG22

OPTIONS: STK:8R841388F ENG:3.8_Lite SMP1

LINE	OPCODE	TECH	TYPE	HOURS	LIST	NET	TOTAL
2	WWF	WIND SHIELD FLUID			2.80	2.80	5.60

P** ROTATE TIRES, CHECK TIRE CONDITION, AND INFLATE TIRES TO PRESSURE LISTED ON DOOR PLACARD.							
RT ROTATE TIRES, CHECK TIRE CONDITION, AND INFLATE TIRES TO PRESSURE LISTED ON DOOR PLACARD.							
195437	HFM			0.40		29.95	29.95

ESTIMATE: 1,760.28 13AUG22 13:45 SA: 250858
 CONTACT: *****

PROVISIONS AND MATERIALS

94.87
 YOU MAY RECEIVE A SATISFACTION SURVEY BY E-MAIL. IF YOU'RE UNABLE TO ANSWER EXCELLENT TO ALL THE QUESTIONS PLEASE CONTACT OUR SERVICE DEPARTMENT. YOUR COMPLETE SATISFACTION IS ALWAYS #1. THANK YOU FOR COMING TO LITHIA FORD OF GRAND FORKS!! OUR PARTS AND SERVICE DEPTS ARE OPEN SATURDAY

COST, SALE, & COMP TOTALS 73174 230967 0

"I acknowledge notice and oral approval of an increase in the original estimated price. Signature or initials"		DESCRIPTION	LABOR AMOUNT	1156.42
STATEMENT OF DISCLAIMER AND ARBITRATION AGREEMENT			PARTS AMOUNT	1153.25
In the course of servicing OE equivalent parts may be used.			GAS, OIL, LUBE	0.00
The factory warranty constitutes all of the warranties with respect to the sale of this item/items. The Seller hereby expressly disclaims all warranties either express or implied, including any implied warranty of merchantability or fitness for a particular purpose. Seller neither assures nor authorizes any other person to assume for it any liability in connection with the sale of this item/items. Any dispute between customer and the dealership arising from or related to this vehicle or this transaction will be settled by mandatory and binding arbitration pursuant to the Federal Arbitration Act 9 U.S.C § 1 et. seq. The arbitration shall be conducted by a single arbitrator. The arbitrator may grant whatever relief the parties may be entitled to at law or in equity.			SUBLET AMOUNT	0.00
CUSTOMER SIGNATURE			MISC. CHARGES	94.87
			TOTAL CHARGES	2404.54
			LESS INS/DED/DIS	0.00
			SALES TAX	0.00
			PLEASE PAY THIS AMOUNT	2404.54
			TOTALS	

INTERNAL

Invoice #: 343790

Tag #: AO1388



2273 32nd AVENUE S - GRAND FORKS, ND 58201
PHONE: (701) 746-6411 - FAX: (701) 787-8912
REMIT PAYMENT TO: LITHIA MOTORS SUPPORT SERVICES
PO BOX 679311, Dallas, TX 75267-9811

Home: Bus: Customer #:

Cell: Email: Service Advisor: 250858 AARON OLSON

Table with columns: COLOR, YEAR, MAKE/MODEL, VIN, LICENSE, MILEAGE IN, MILEAGE OUT, DEL DATE, PROD. DATE, WARR. EXP., PROMISED, PO NO., RATE, PAYMENT, INV. DATE, R.O. OPENED, READY

OPTIONS: STK:8R841388F ENG:3.8 Liter SMPI

Main service list table with columns: LINE, OPCODE, TECH, TYPE, HOURS, LIST, NET, TOTAL. Includes items like WPM3045 MOTOR, 42783 ARM, WW1602PF BLADE ASY - WIPER, etc.

Bottom section containing a signature line, a disclaimer/agreement section, and a detailed breakdown of charges (LABOR, PARTS, GAS, OIL, LUBE, etc.) with a vertical 'TOTALS' column.

INTERNAL

Invoice #: 343790

Tag #: AO1388



LITHIA FORD LINCOLN OF GRAND FORKS #176

2273 32nd AVENUE S - GRAND FORKS, ND 58201
PHONE: (701) 746-6411 - FAX: (701) 787-8912
REMIT PAYMENT TO: LITHIA MOTORS SUPPORT SERVICES
PO BOX 679811, Dallas, TX 75267-9811

Home: Bus: Customer #:

Cell: Email: Service Advisor: 250858 AARON OLSON

Table with columns: COLOR, YEAR, MAKE/MODEL, VIN, LICENSE, MILEAGE IN, MILEAGE OUT, DEL DATE, PROD. DATE, WARR. EXP., PROMISED, PO NO., RATE, PAYMENT, INV. DATE, R.O. OPENED, READY. Includes values like 08, CHRYSLER TOWN & COUN, 2A8HR54F48R841388, 185700, 185700, 04AUG22, 16.00 13AUG22, 0.00, CASH, 15AUG22, 17:44 12AUG22, 16:33 15AUG22.

OPTIONS: STK:8R841388F ENG:3.8 Liter SMPI

Main service list table with columns: LINE, OPCODE, TECH, TYPE, HOURS, LIST, NET, TOTAL. Includes items like A PERFORM VALUE AUTO PREP, B PERFORM FORD VEHICLE MULTIPPOINT INSPECTION, C** INSTALL ASSURED PREMIUM VISION WIPER BLADES, D** UNDER HOOD WASHER JETS BROKEN, E** REAR HATCH WIPER MOTOR INOP.

"I acknowledge notice and oral approval of an increase in the original estimated price. Signature or initials"
STATEMENT OF DISCLAIMER AND ARBITRATION AGREEMENT
In the course of servicing, OE equivalent parts may be used.
The factory warranty constitutes all of the warranties with respect to the sale of this item/items. The Seller hereby expressly disclaims all warranties either express or implied, including any implied warranty of merchantability or fitness for a particular purpose. Seller neither assumes nor authorizes any other person to assume for it any liability in connection with the sale of this item/items. Any dispute between customer and the dealership arising from or related to this vehicle or this transaction will be settled by mandatory and binding arbitration pursuant to the Federal Arbitration Act 9 U.S.C § 1 et. seq. The arbitration shall be conducted by a single arbitrator. The arbitrator may grant whatever relief the parties may be entitled to at law or in equity.

ON BEHALF OF SERVICING DEALER, I HEREBY CERTIFY THAT THE INFORMATION CONTAINED HEREON IS ACCURATE UNLESS OTHERWISE SHOWN. SERVICES DESCRIBED WERE PERFORMED AT NO CHARGE TO OWNER. THERE WAS NO INDICATION FROM THE APPEARANCE OF THE VEHICLE OR OTHERWISE, THAT ANY PART REPAIRED OR REPLACED UNDER THIS CLAIM HAD BEEN CONNECTED IN ANY WAY WITH ANY ACCIDENT, NEGLIGENCE OR MISUSE. RECORDS SUPPORTING THIS CLAIM ARE AVAILABLE FOR (1) YEAR FROM THE DATE OF PAYMENT NOTIFICATION AT THE SERVICING DEALER FOR INSPECTION BY MANUFACTURER'S REPRESENTATIVE.

Summary table with columns: LABOR AMOUNT, PARTS AMOUNT, GAS, OIL, LUBE, SUBLET AMOUNT, MISC. CHARGES, TOTAL CHARGES, LESS INS/DED/DIS, SALES TAX, PLEASE PAY THIS AMOUNT. Includes a vertical 'TOTALS' column.



City of Thief River Falls
 405 3rd Street East
 Thief River Falls, MN 56701

Receipt Number: R00083182

Cashier Name: JRD

Terminal Number: 7

Receipt Date: 12/30/2022 1:46:39 PM

NORTHLAND TAXI

Trans Code: MISC - MISCELLANEOUS RECEIPT

Name: NORTHLAND TAXI

\$30.00

Product: Admin Taxi License (1st taxi)

Units: 0.00 Amount: 30.00

NORTHLAND TAXI 30.00

205 30.00

100-4670-53218 -30.00

Total Balance Due: \$30.00

Payment Method: Cash

Payor: NORTHLAND TAXI

Reference:

Amount: \$30.00

Total Payment Received: \$30.00

Change: \$0.00

CITY OF THIEF RIVER FALLS "ASE" MECHANIC INSPECTION

NAME OF COMPANY	Northland Taxi
REGISTERED OWNER OF VEHICLE	Randall Anenson
ADDRESS	518 Knight Ave. N. Thief River Falls, MN 56701
PHONE(S)	218-681-6666 / 218-416-0888

VEHICLE INFORMATION	
MODEL YEAR	2008
MAKE	Chrysler
MODEL	Town & Country
VIN#	2A8HR54P48R841388
LICENSE PLATE #/STATE	

CODE	ITEM	PASS	FAIL
A	GLASS	✓	
B	MIRRORS	✓	
C	SEATS	✓	
D	SEAT BELTS	✓	
E	HEADLIGHTS	✓	
F	TAIL LIGHTS	✓	
G	TURN SIGNALS	✓	
H	BRAKE LIGHTS	✓	
I	TAG LIGHTS	✓	
J	BACK UP LIGHTS	✓	
K	WIPERS	✓	

CODE	ITEM	PASS	FAIL
L	HORN	✓	
M	TIRES	✓	
N	BRAKES	✓	
O	EMERGENCY BRAKES	✓	
P	EXHAUST	✓	
Q	GAS	✓	
R	STEERING	✓	
S	DRIVE LINE/SUSPENSION	✓	
T	SPARE TIRE	✓	
U	ENGINE	✓	

REMARKS					
INSPECTION	PASS	<input checked="" type="checkbox"/>	FAIL	<input type="checkbox"/>	
MECHANIC'S NAME/SIGNATURE		<i>WAS [Signature]</i>			
IS MECHANIC "ASE" CERTIFICATION ATTACHED? (REQUIRED)		YES	<input type="checkbox"/>	NO	<input checked="" type="checkbox"/>

TAXI INSPECTION FORM CODES AND DEFINITIONS
REASON FOR FAILURE

A	GLASS: ANY BROKEN OR MISSING GLASS; WINDSHIELD CRACKS INTERFERING WITH DRIVER'S VISION OR PASSENGER SAFETY
B	MIRRORS: MISSING, CREAKED OR BROKEN TO THE EXTENT TO OBSTRUCT VISION
C	SEATS: BROKEN SPRINGS, TEARS OR RIPS IN UPHOLSTERY OVER TWO INCHES THAT COULD INTERFERE WITH ENTRY AND EXIT
D	SEAT BELTS: ANY MISSING COMPONENT; ANY LOCKS THAT WILL NOT ENGAGE OR DISENGAGE; TEARS OR RIPS IN FABRIC BELTS
E	HEADLIGHTS: ANY LIGHT NOT FUNCTIONING TO INCLUDE HIGH AND LOW BEAMS
F	TAIL LIGHTS: ANY BULB NOT WORKING; GLASS OR PLASTIC COVER BROKEN
G	TURN SIGNALS: ANY BULB NOT WORKING; GLASS OR PLASTIC COVER BROKEN
H	BRAKE LIGHTS: ANY BULB NOT WORKING; GLASS OR PLASTIC COVER BROKEN
I	TAG LIGHTS: ANY BULB NOT WORKING; GLASS OR PLASTIC COVER BROKEN
J	BACK UP LIGHTS: ANY BULB NOT WORKING; GLASS OR PLASTIC COVER BROKEN
K	WIPERS: NOT WORKING, BLADES HARD, CRACKED, FRAYED OR RIPPED

L	HORN: INOPERATIVE
M	TIRES: TREAD DEPTH LESS THAN 4/32", TIRES THAT HAVE VISIBLE CORD OR METAL, REGROOVED OR SIDE PLUG
N	BRAKES: FRONT/REAR DISK BRAKE LESS THAN 15% USABLE PAD REMAINING, ROTOR NOT WITHIN MANUFACTURER SPEC. REAR DRUMS: LESS THAN 15% USABLE SHOE REMAINING, LEAKING IN CALIPER, WHEEL CYLINDER, MASTER CYLINDER AND/OR LINE
O	EMERGENCY BRAKES: NOT WORKING/NOT HOLDING VEHICLE
P	LEAKS: EXHAUST LEAK
Q	GAS: GAS LEAK
R	STEERING: LOOSENESS ANYWHERE EXCEEDING 1/8", MISSING BOLTS OR BENT COMPONENTS, POWER STEERING PUMP OR LINE LEAKS
S	DRIVE LINE/SUSPENSION: SHOCKS LEAKING, WON'T RECOVER WHEN VEHICLE IS PUSHED DOWNWARD; BROKEN OR DETERIORATED MOTOR OR TRANSMISSION MOUNTS; TRANSMISSION NOT WORKING PROPERLY, NOT SHIFTING SMOOTHLY; U-JOINTS LOOSE, DRIVE SHAFT BENT, SPRINGS CRACKED OR BROKEN
T	SPARE TIRE: TIRE DEPTH LESS THAN 4/32", NO CAR JACK AND/OR NO TIRE CHANGING TOOL
U	ENGINE: ENGINE DOES NOT RUN SMOOTHLY; KNOCKS, HEAVY EXHAUST SMOKE

VEHICLE CHECK-UP



MULTI-POINT INSPECTION AS RECOMMENDED BY FORD MOTOR COMPANY

CUSTOMER INFORMATION

Date: _____ RO/Tag#: _____
 Name: _____ Phone#: () _____
 Email: _____
 VIN#: _____
 Year/Make/Model: _____ Plate#: _____
 Odometer: _____ Inspect. Month: _____
 Modern Activation: YES NO OTA Software Updates Complete: YES NO
 Dash Lights: TPMS On TPMS Flashing Warning Indicator/Messages ABS
 FordPass/Lincoln Access Rewards Member: YES NO FordPass/Lincoln Way Member ID: _____
 Ford/Lincoln Protect (Extended Service Plan): YES NO

EXTERIOR BODY

May contribute to vehicle efficiency and promote a greener environment
 Check and OK at this time May require future attention Requires immediate attention

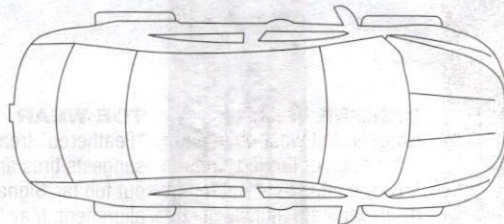

Note any exterior body damage or defects on diagram

SCHEDULED MAINTENANCE

Serviced	DUE	Serviced	DUE
<input type="checkbox"/>	<input checked="" type="checkbox"/> THE WORKS	<input type="checkbox"/>	<input type="checkbox"/> Engine Air Filter
<input type="checkbox"/>	<input checked="" type="checkbox"/> Oil Change & Filter	<input type="checkbox"/>	<input type="checkbox"/> Engine Coolant
<input type="checkbox"/>	<input checked="" type="checkbox"/> Tire Rotation	<input type="checkbox"/>	<input type="checkbox"/> Transmission Fluid &/or Filter
<input type="checkbox"/>	<input checked="" type="checkbox"/> Multi-Point Inspection	<input type="checkbox"/>	<input type="checkbox"/> Cabin Air Filter N/A
<input type="checkbox"/>	<input checked="" type="checkbox"/> Fuel Filter N/A	<input type="checkbox"/>	<input type="checkbox"/> Spark Plugs
<input type="checkbox"/> K Scheduled Maintenance			

This is only a partial list maintenance items and is NOT all-inclusive. Please consult your Owner's Manual or visit FordOwner.com for vehicle specific maintenance requirements. N/A is circled if certain part is not applicable.

FLUIDS

OK FILL Engine Oil Power Steering
 Brake Reservoir Window Washer
 Transmission (if equipped with dipstick) Coolant Recovery Reservoir

LIGHTS/HORN/WIPERS

Serviced Horn Serviced Front Wipers Serviced Rear Wipers (if equipped)
 Serviced Windshield Serviced Front Lighting Serviced Rear Lighting - 4-Way Flasher, Taillights, Stop Lights, Plate Lights

UNDER HOOD

Serviced Battery State of Health Battery Condition
 Factory spec cold cranking amps _____ Actual cold cranking amps 40
 Cooling System - Hoses and Piping
 Engine Air Filter
 Engine Drive Belt(s)
 Cabin Air Filter N/A

TIRES

Serviced	Tire Tread Depth	7/32" or Greater / Over 5mm	6/32" to 4/32" / 5mm to 3mm	3/32" or Less / Less than 3mm
<input checked="" type="checkbox"/>	Left Front Tire Condition:	<input checked="" type="checkbox"/>	<input checked="" type="checkbox"/> TPMS Sensor	<input checked="" type="checkbox"/> Sensor Nut/Valve Core/Cap
<input checked="" type="checkbox"/>	Right Front Tire Condition:	<input checked="" type="checkbox"/>	<input checked="" type="checkbox"/> TPMS Sensor	<input checked="" type="checkbox"/> Sensor Nut/Valve Core/Cap
<input checked="" type="checkbox"/>	Left Rear Tire Condition:	<input checked="" type="checkbox"/>	<input checked="" type="checkbox"/> TPMS Sensor	<input checked="" type="checkbox"/> Sensor Nut/Valve Core/Cap
<input checked="" type="checkbox"/>	Right Rear Tire Condition:	<input checked="" type="checkbox"/>	<input checked="" type="checkbox"/> TPMS Sensor	<input checked="" type="checkbox"/> Sensor Nut/Valve Core/Cap
<input checked="" type="checkbox"/>	Full Size/Temp Spare Tire Condition:	<input checked="" type="checkbox"/>	<input checked="" type="checkbox"/> TPMS Sensor	<input checked="" type="checkbox"/> Sensor Nut/Valve Core/Cap

Tread Depth: 9 Tire PSI: 36 Age: 21 *
 Tread Depth: 4 Tire PSI: 1 Age: 21 *
 Tread Depth: 8 Tire PSI: 1 Age: 21 *
 Tread Depth: 7 Tire PSI: 1 Age: 21 *
 Tread Depth: _____ Tire PSI: _____ Age: _____ *

Size: _____ Other/Comments: _____

*Tires should be replaced after 6 years.

BRAKES

Serviced	Brake Lining	5mm or More or Over 7/32" (Disc) or Over 2mm or 3/32" (Drum)	3.01 to 4.99mm or 4/32" to 7/32" (Disc) or 1.01 to 2mm or 2/32" to 3/32" (Drum)	3mm or Less or Under 4/32" (Disc) or 1mm or Less or Under 2/32" (Drum)	NOT INSPECTED
<input checked="" type="checkbox"/>	Left Front Brake	Pad Thickness: 10mm	Rotor Actual:	Rotor Minimum Spec:	<input type="checkbox"/>
<input checked="" type="checkbox"/>	Right Front Brake	Pad Thickness: 10mm	Rotor Actual:	Rotor Minimum Spec:	<input type="checkbox"/>
<input checked="" type="checkbox"/>	Left Rear Brake	Pad/Shoe Thickness: 7mm	Rotor/Drum Actual:	Rotor/Drum Minimum Spec:	<input type="checkbox"/>
<input checked="" type="checkbox"/>	Right Rear Brake	Pad/Shoe Thickness: 7mm	Rotor/Drum Actual:	Rotor/Drum Minimum Spec:	<input type="checkbox"/>

UNDERCARRIAGE

<input checked="" type="checkbox"/>	Left Front suspension, struts, steering linkage, brake lines/hoses	Notes:
<input checked="" type="checkbox"/>	Right Front suspension, struts, steering linkage, brake lines/hoses	Notes:
<input checked="" type="checkbox"/>	Left Rear suspension, shocks/struts, linkage, brake lines/hoses	Notes:
<input checked="" type="checkbox"/>	Right Rear suspension, shocks/struts, linkage, brake lines/hoses	Notes:
<input checked="" type="checkbox"/>	Exhaust System	Notes:
<input checked="" type="checkbox"/>	Drivetrain	Notes:

RELATED	DESCRIPTION	PARTS	LABOR	TOTAL ESTIMATE
IMMEDIATE				
MAINTENANCE				
TOTAL				

Advisor: _____ Customer Signature: _____
 Technician: _____ Technician: _____



TOE WEAR
"Feathered" tread wear pattern suggests tires are turned in or out too far. Signals need for alignment. May be caused by worn shocks/struts.



CAMBER WEAR
Exaggerated wear on inner or outer edge of tire indicates tires are tilted in or out too far (from vertical). Signals need for alignment. May be caused by worn shocks/struts.

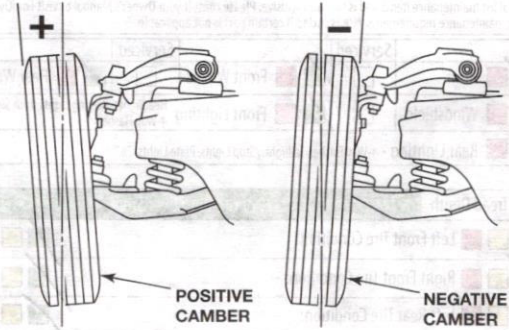
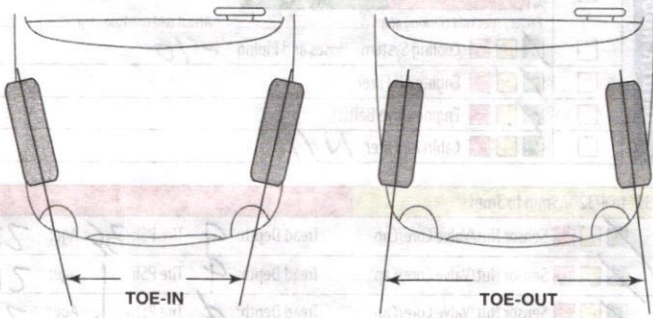

DISC BRAKE

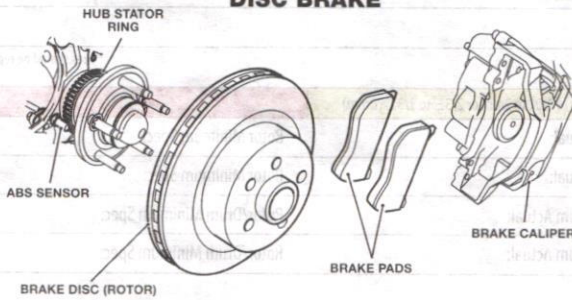

DRUM BRAKE

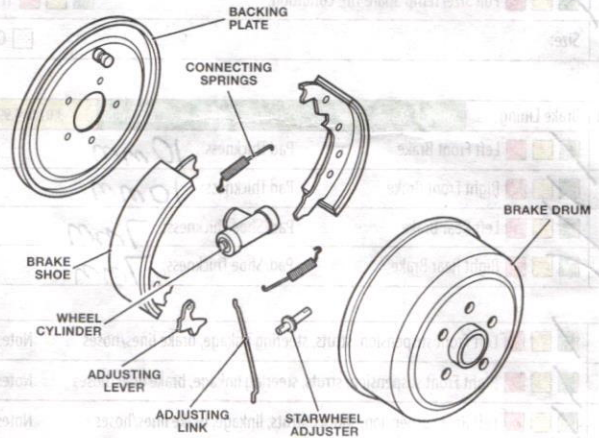

SUSPENSION

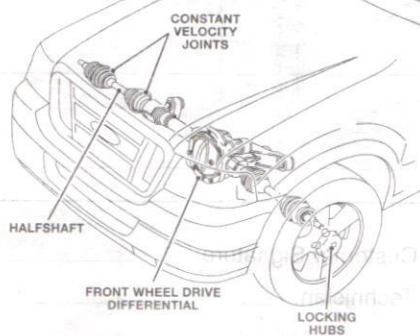
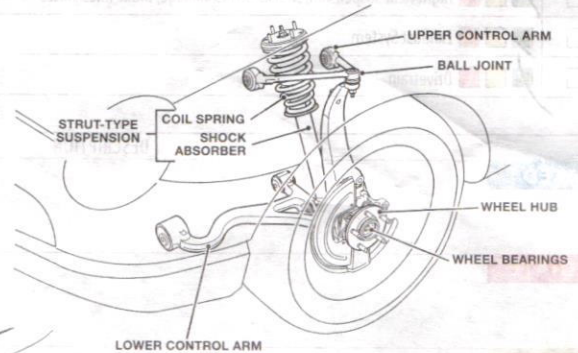
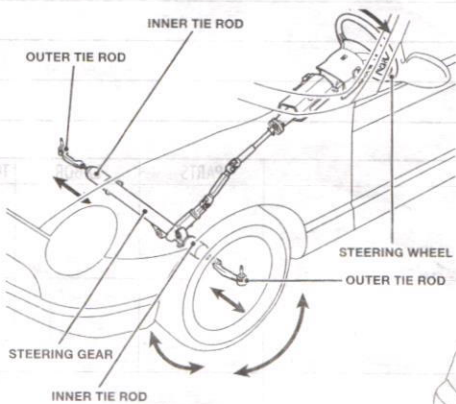

CUSTOMER #: 19998

172183



INVOICE

THIEF RIVER FORD, INC.
802 3rd Street West
Thief River Falls, MN 56701
(800) 295-3673 · (218) 681-2660

TAXI NORTHLAND
518 N KNIGHT AVE
THIEF RIVER FALLS, MN 56701
HOME:218-681-6666 CONT:218-681-6666
BUS: CELL:218-416-0888

PAGE 1

SERVICE ADVISOR: 27 JACKIE LEE

Table with columns: COLOR, YEAR, MAKE/MODEL, VIN, LICENSE, MILEAGE IN / OUT, TAG, DEL. DATE, PROD. DATE, WARR. EXP., PROMISED, PO NO., RATE, PAYMENT, INV. DATE. Includes vehicle details like MAROON 08 CHRYSLER TOWN AND CO and service dates 01JAN08 DD to 02JAN23.

Table with columns: LINE, OPCODE, TECH, TYPE, HOURS, LIST, NET, TOTAL. Lists inspection items such as 'A QUICK LANE MULTI-POINT INSPECTION' and 'B FULL INSPECTION' with associated costs.

Table with columns: WARRANTY DISCLAIMER, SHOP SUPPLY COSTS, DESCRIPTION, TOTALS. Includes legal disclaimers and a summary of charges like LABOR AMOUNT, PARTS AMOUNT, and SALES TAX.

SERVICE HOURS: Monday - Thursday 7:30am - 5:30pm · Friday 7:30am - 5:00pm

CUSTOMER

CUSTOMER #: 19998

172183



INVOICE

THIEF RIVER FORD, INC.

802 3rd Street West

Thief River Falls, MN 56701

(800) 295-3673 · (218) 681-2660

TAXI NORTHLAND
518 N KNIGHT AVE
THIEF RIVER FALLS, MN 56701
HOME:218-681-6666 CONT:218-681-6666
BUS: CELL:218-416-0888

PAGE 2

SERVICE ADVISOR: 27 JACKIE LEE

COLOR	YEAR	MAKE/MODEL	VIN	LICENSE	MILEAGE IN / OUT	TAG	
MAROON	08	CHRYSLER TOWN AND CO	2A8HR54P48R841388		186193/186193		
DEL. DATE	PROD. DATE	WARR. EXP.	PROMISED	PO NO.	RATE	PAYMENT	INV. DATE
01JAN08 DD						CASH	02JAN23
R.O. OPENED	READY	OPTIONS: DLR:58Y640 ENG:3.8_Liter_SMPI					
10:58	02JAN23	11:29	02JAN23				

LINE	OPCODE	TECH	TYPE	HOURS	LIST	NET	TOTAL
------	--------	------	------	-------	------	-----	-------

YOU MAY RECEIVE A SATISFACTION SURVEY BY E-MAIL. IF YOU ARE UNABLE TO ANSWER EXCELLENT OR STRONGLY AGREE TO ALL QUESTIONS, PLEASE CONTACT OUR SERVICE DEPARTMENT. YOUR SATISFACTION IS OUR #1 GOAL. THANKS FOR YOUR BUSINESS!

WARRANTY DISCLAIMER: ALL PARTS AND ACCESSORIES ARE SOLD AND ALL REPAIRS ARE PROVIDED BY THE DEALERSHIP AS-IS. THE DEALERSHIP HEREBY EXPRESSLY DISCLAIMS ALL WARRANTIES, EXPRESS AND IMPLIED, INCLUDING ANY IMPLIED WARRANTIES OF MERCHANTABILITY AND FITNESS FOR A PARTICULAR PURPOSE, AND NEITHER ASSUMES NOR AUTHORIZES ANY OTHER PERSON TO ASSUME FOR IT ANY LIABILITY IN CONNECTION WITH THE SALE OF PARTS OR PRODUCTS OR THE REPAIR. THE ONLY WARRANTIES ON PARTS AND ACCESSORIES OR REPAIRS ARE THOSE WHICH MAY BE OFFERED BY THE VEHICLE MANUFACTURER OR THE PARTS MANUFACTURER OR DISTRIBUTOR AND ONLY SUCH MANUFACTURER OR DISTRIBUTOR SHALL BE LIABLE FOR PERFORMANCE UNDER SUCH WARRANTIES. CUSTOMER SHALL NOT BE ENTITLED TO RECOVER FROM THE DEALERSHIP ANY CONSEQUENTIAL DAMAGES, DAMAGES TO PROPERTY, DAMAGES FOR LOSS OF USE, LOSS OF TIME, LOSS OF PROFIT OR INCOME, OR ANY OTHER INCIDENTAL DAMAGES.

By signing below, you acknowledge that you were notified of and authorized the Dealership to perform the services/repairs itemized in this Invoice and that you received (or had the opportunity to inspect) any replaced parts as requested by you. The vehicle is being returned to you in exchange for your payment of the Amount Due.

***SHOP SUPPLY COSTS:**
We have added a charge equal to 12% of the total cost of labor, not to exceed \$25.00, to the Repair Order for shop supplies used in connection with this repair.

ALL PARTS ARE NEW ORIGINAL EQUIPMENT PARTS UNLESS OTHERWISE INDICATED.

DESCRIPTION	TOTALS
LABOR AMOUNT	30.00
PARTS AMOUNT	0.00
GAS, OIL, LUBE	0.00
SUBLET AMOUNT	0.00
MISC. CHARGES *	0.00
TOTAL CHARGES	30.00
LESS INSURANCE	0.00
SALES TAX	0.00
PLEASE PAY THIS AMOUNT	30.00

DATE CUSTOMER SIGNATURE AUTHORIZED DEALERSHIP REPRESENTATIVE SIGNATURE

SERVICE HOURS: Monday - Thursday 7:30am - 5:30pm · Friday 7:30am - 5:00pm

INSURANCE IDENTIFICATION CARD

MN
(STATE)

COMPANY NUMBER
10243

COMPANY
National Continental Insurance Company

COMMERCIAL PERSONAL

POLICY NUMBER
CMN000-5173-500-2

EFFECTIVE DATE
1/1/2023

EXPIRATION DATE
1/9/2023

YEAR
2008

MAKE/MODEL
Chrysler

VEHICLE IDENTIFICATION NUMBER
Town & Country 2A8HR54P48R841388

AGENCY/COMPANY ISSUING CARD

North Risk Partners
2017 Highway 59 SE

Thief River Falls MN 56701 (218) 681-1714

INSURED

Randall Anenson
518 Knight Ave N

Thief River Falls MN 56701

SEE IMPORTANT NOTICE ON REVERSE SIDE

INVOICE

Printed Date: 01/04/2023 Work Completed: 01/04/2023

NORTHLAND TAXI - RANDALL ANENSON

518 KNIGHT AVE N
 Thief River Falls, MN 56701
 Cellular 218-416-0888 -- Home 218-681-6666

2008 Chrysler - Town & Country Limited - 4L, V6 (241CI) VIN(X)
 Lic # : N/A Odometer In : 186238

VIN # : 2A8HR54P4841388

Part Description / Number	Qty	Sale	Ext	Labor Description	Ext
---------------------------	-----	------	-----	-------------------	-----

Shop Supplies And Waste Disposal			1.00	INSPECTED FOR SAFETY. DID NOT FIND ANY PROBLEMS AT THIS TIME NO LICENSE PLATE ON VEHICLE	27.50
----------------------------------	--	--	------	---	-------

pd cash

*Rec'd 1/4/2023
RO*

Org Estimate 0.00 Revisions 0.00 Current Estimate 0.00

Labor:	27.50
Parts:	1.00
SubTotal:	28.50
Tax:	0.07
Total:	28.57
Bal Due:	\$28.57

COPY

[Payments -]

Vehicle Received: 1/4/2023

Customer Number : 9461

VEHICLES LEFT HERE FOR MORE THEN 10 DAYS AFTER REPAIR IS COMPLETED WILL BE SUBJECT TO A \$15.00 PER DAY STORAGE FEE

Signature _____ Date _____

CITY OF THIEF RIVER FALLS "ASE" MECHANIC INSPECTION

NAME OF COMPANY	Northland Taxi
REGISTERED OWNER OF VEHICLE	Randall Anerson
ADDRESS	518 Knight Ave. N. Thief River Falls, MN 56701
PHONE(S)	218-416-0888 / 218-681-6666

VEHICLE INFORMATION	
MODEL YEAR	2008
MAKE	Chrysler
MODEL	Town & Country
VIN#	2A8HR54P4841388
LICENSE PLATE #/STATE	

CODE	ITEM	PASS	FAIL
A	GLASS	✓	
B	MIRRORS	✓	
C	SEATS	✓	
D	SEAT BELTS	✓	
E	HEADLIGHTS	✓	
F	TAIL LIGHTS	✓	
G	TURN SIGNALS	✓	
H	BRAKE LIGHTS	✓	
I	TAG LIGHTS	✓	
J	BACK UP LIGHTS	✓	
K	WIPERS	✓	

CODE	ITEM	PASS	FAIL
L	HORN	✓	
M	TIRES	✓	
N	BRAKES	✓	
O	EMERGENCY BRAKES	✓	
P	EXHAUST	✓	
Q	GAS	✓	
R	STEERING	✓	
S	DRIVE LINE/SUSPENSION	✓	
T	SPARE TIRE	✓	
U	ENGINE	✓	

REMARKS			
INSPECTION	PASS ✓	FAIL	
MECHANIC'S NAME/SIGNATURE		<i>Randall Anerson</i>	
IS MECHANIC "ASE" CERTIFICATION ATTACHED? (REQUIRED)		YES	NO

TAXI INSPECTION FORM CODES AND DEFINITIONS
REASON FOR FAILURE

A	GLASS: ANY BROKEN OR MISSING GLASS; WINDSHIELD CRACKS INTERFERING WITH DRIVER'S VISION OR PASSENGER SAFETY
B	MIRRORS: MISSING, CREAKED OR BROKEN TO THE EXTENT TO OBSTRUCT VISION
C	SEATS: BROKEN SPRINGS, TEARS OR RIPS IN UPHOLSTERY OVER TWO INCHES THAT COULD INTERFERE WITH ENTRY AND EXIT
D	SEAT BELTS: ANY MISSING COMPONENT; ANY LOCKS THAT WILL NOT ENGAGE OR DISENGAGE; TEARS OR RIPS IN FABRIC BELTS
E	HEADLIGHTS: ANY LIGHT NOT FUNCTIONING TO INCLUDE HIGH AND LOW BEAMS
F	TAIL LIGHTS: ANY BULB NOT WORKING; GLASS OR PLASTIC COVER BROKEN
G	TURN SIGNALS: ANY BULB NOT WORKING; GLASS OR PLASTIC COVER BROKEN
H	BRAKE LIGHTS: ANY BULB NOT WORKING; GLASS OR PLASTIC COVER BROKEN
I	TAG LIGHTS: ANY BULB NOT WORKING; GLASS OR PLASTIC COVER BROKEN
J	BACK UP LIGHTS: ANY BULB NOT WORKING; GLASS OR PLASTIC COVER BROKEN
K	WIPERS: NOT WORKING, BLADES HARD, CRACKED, FRAYED OR RIPPED

L	HORN: INOPERATIVE
M	TIRES: TREAD DEPTH LESS THAN 4/32", TIRES THAT HAVE VISIBLE CORD OR METAL, REGROOVED OR SIDE PLUG
N	BRAKES: FRONT/REAR DISK BRAKE LESS THAN 15% USABLE PAD REMAINING, ROTOR NOT WITHIN MANUFACTURER SPEC. REAR DRUMS: LESS THAN 15% USABLE SHOE REMAINING, LEAKING IN CALIPER, WHEEL CYLINDER, MASTER CYLINDER AND/OR LINE
O	EMERGENCY BRAKES: NOT WORKING/NOT HOLDING VEHICLE
P	LEAKS: EXHAUST LEAK
Q	GAS: GAS LEAK
R	STEERING: LOOSENESS ANYWHERE EXCEEDING 1/8", MISSING BOLTS OR BENT COMPONENTS, POWER STEERING PUMP OR LINE LEAKS
S	DRIVE LINE/SUSPENSION: SHOCKS LEAKING, WON'T RECOVER WHEN VEHICLE IS PUSHED DOWNWARD; BROKEN OR DETERIORATED MOTOR OR TRANSMISSION MOUNTS; TRANSMISSION NOT WORKING PROPERLY, NOT SHIFTING SMOOTHLY; U-JOINTS LOOSE, DRIVE SHAFT BENT, SPRINGS CRACKED OR BROKEN
T	SPARE TIRE: TIRE DEPTH LESS THAN 4/32", NO CAR JACK AND/OR NO TIRE CHANGING TOOL
U	ENGINE: ENGINE DOES NOT RUN SMOOTHLY; KNOCKS, HEAVY EXHAUST SMOKE